

Catalog #:	
Project:	
Type:	Date:
Notes:	

Led shoebox light



Key Features

OPTICS:

- SB07B series Light engines are available in standard 4000K, 5000K and 5700K configurations.
- Type III(150*85degree) beam angle.

ELECTRICAL:

- Input voltage:100-277V&277-480V
- 1-10V dimming
- THD: ≤20%, Power Factor: ≥0.9.

CONTROLS:

- Optional for Photocell&Surge protector

INSTALLATION:

- AM(slip fitter)bracket for round pole
- A&D(Universal)bracket for all the appliaction, such as square pole, round pole, wall.

LIFESPAN:

- Estimated 50,000-hour LED lifespan based on IES LM-80 results and TM-21 calculations.

LISTINGS:

- DesignLights Consortium® (DLC) Premium qualified and DLC qualified.
- UL listed for wet locations.
- Rated for ambient operating temperature -40°F to 113°F (-40°C to 45°C).

Optional Accessories



Photocell



A&D Bracket

Model No	Power (W)	Voltage	CRI	5000K		Dimension	Weight (lbs)
				Lumens	Efficacy		
ML-S-G07B-150WCT3A2-BH3NPAM50	150W	100-277V	>70	19500lm	130lm/w	AM: 20.8×13.1×3.6"	14.52
ML-S-G07B-150WCT3H2-BHAM50	150W	277-480V	>70	19950lm	133lm/w	A&D: 23.2×13.1×6.3"	14.52
ML-S-G07B-300WCT3A2-BH3NPAM50	300W	100-277V	>70	39000lm	130lm/w	AM: 27.6×13.1×3.8"	21.78
ML-S-G07B-300WCT3H2-BHAM50	300W	277-480V	>70	39600lm	132lm/w	A&D: 29.9×13.1×6.3"	21.78

Dimensions

150W

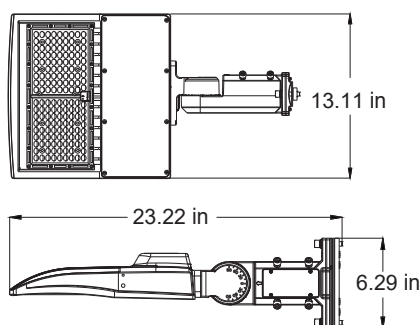
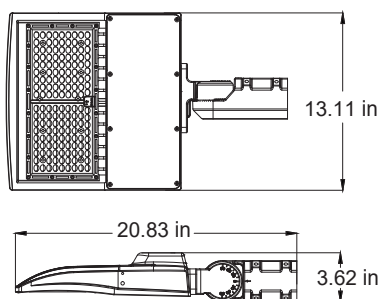

300W

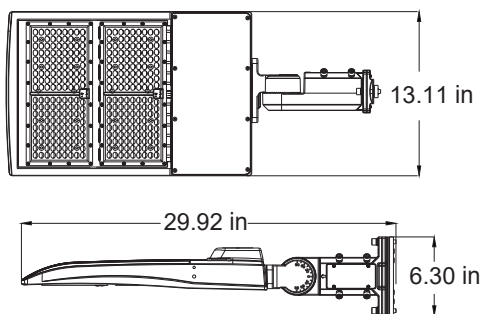
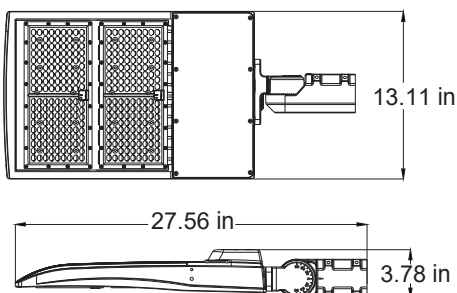

Installation Diagram

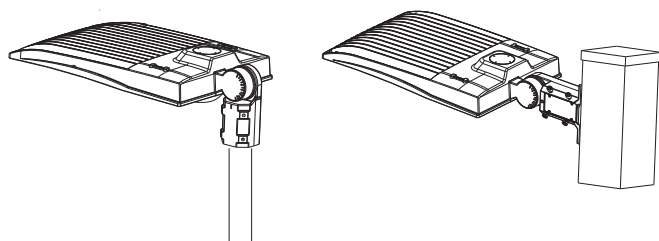

Distribution Diagram

